

# Grade Level Spill Containers

## EBW's 702, 705, 715 & 725 Series FlexCatch® Grade Level Spill Containers

EBW's FlexCatch Spill Containers are designed to collect spilled product that occurs during normal tank filling on underground storage tanks. This usually occurs at the fill and vapor connections or in the event of a tank overflow. EBW offers three base styles to choose from depending on your installation requirements. Threaded base models are offered in Cast Iron or Composite. Slip-On (Retrofit) models use a gasketed flanged bolt system to secure the spill bucket to the riser pipe. Slip-On (Retrofit) models are designed to eliminate the need to remove the riser pipe from the underground tank when installing. The tank is simply slid over the existing 4" riser pipe and secured in place with a flanged bolt system.



### Features:

#### **Solid Construction**

The durable and flexible polyethylene shell is designed to move with natural ground movements. The shell is equipped with a gravel guard to prevent backfill material from filling in around the movable shell, eliminating problems with ground movement.

#### **Cast Iron or Composite Base**

EBW's base design is the most reliable in the industry. The polyethylene shell is bolted between the cast iron or composite base, a durable cork gasket and special backer plates ensuring a long lasting, watertight seal. Both bases easily thread onto a 4" tank riser.



#### **Heavy Duty Cast Iron Deflector Ring**

The cast iron ring provides protection from heavy traffic and truck plows. Its unique design allows for water to run away

from the spill container top, eliminating excessive water collection in the bucket. The cast iron ring is mounted to the bucket by bolting the spill bucket between the cast iron ring and specially designed backer plates. This helps eliminate the chance of damage due to excessive movements.

#### **Many Cover Options**

EBW's colored composite covers help prevent cross contamination and eliminate the need to constantly paint, by molding the permanent color into the cover. All spill containers are supplied with a black FRC cover (705-423-01) unless otherwise specified. FRC colored covers for both the rain tight and snap-on models are available in all API color codes. Cast iron and aluminum covers are also available for most rain tight models. An optional watertight aluminum cover is available for all grade level spill containers.



# Grade Level Spill Containers

## Drain Valve

The specially designed drain valve allows emptying of contained product back to the storage tank without messy plugs or pumps. By pulling the key ring located towards the top of the spill container, the valve pushes open to allow product to drain. The drain is equipped with a screen for convenient cleaning.

## Cover Identification Plates

All FRC Colored covers have a recessed area on the top for a product identification plate. The identification plate clearly identifies the product contained in the storage tank and helps to prevent cross contamination. Identification plates are available for all standard API Symbols.

## Highway 20 Rated (DOT H20)

All EBW Spill Containers and Manholes exceed the D.O.T. H20 requirements.

## Capacity

EBW grade level FlexCatch Spill Containers are available in 5 gallon, 15 gallon, and 25 gallon capacity.

## Optional Watertight Aluminum Cover

An optional watertight aluminum cover is available for all grade level spill containers. Used in high water table areas, the mechanical sealing mechanism creates a watertight seal eliminating water from entering the spill container. Each cover is supplied with a special drain valve guide which allows the cover to fit into existing containers.



MODEL	A IN / CM	B IN / CM	C IN / CM
705	17.12/43.48	14.75/37.46	15.69/39.85
715	17.12/43.48	23.50/59.69	22.50/57.15
725	17.12/43.48	24.40/68.58	27.00/68.58

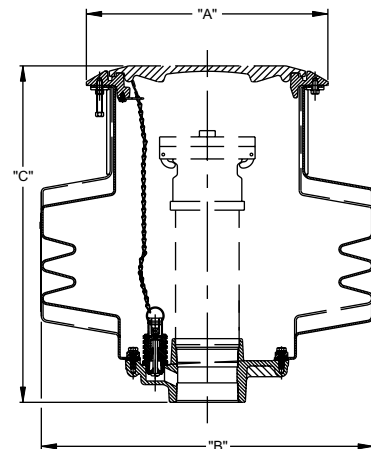

## Materials

Base: Cast Iron or Composite  
 Bucket: Polyethylene  
 Mounting Ring: Cast Iron  
 Cover: Fiber Reinforced Composite (FRC), Cast Iron or Aluminum

# Grade Level Spill Containers

## Ordering Specifications:

### Cast Iron Base Models

Model #	Gal/Liter	Cover Type	Cover Material	Drain	Special	lbs. / kg.
705-470-01	5/19	Rain Tight	FRC, Aluminum	Yes		50 / 23
705-472-01	5/19	Snap-On	FRC	Yes		54 / 25
705-479-65	5/19	Rain Tight	Cast Iron	Yes	Riser, Cap & Adaptor - ULC Listed	56 / 25.4
705-480-01	5/19	Snap-On	FRC	No	Riser, Cap & Adaptor	57 / 26
705-488-01	5/19	Snap-On	FRC	No		54 / 25
705-458-01	5/19	Rain Tight	FRC, CI, AL	No		60 / 27
715-470-01	15/57	Rain Tight	FRC, CI, AL	Yes		58 / 26
715-472-01	15/57	Snap-On	FRC	Yes		62 / 28
715-472-65	15/57	Snap-On	FRC	Yes	Riser, Cap & Adaptor - ULC Listed	65 / 28.1
715-472-66	15/57	Snap-On	FRC	Yes	ULC Listed	62 / 28
715-477-01	15/57	Snap-On	FRC	No		62 / 28
715-479-65	15/57	Rain Tight	CI	Yes	Riser, Cap & Adaptor,	66 / 30
725-470-01	25/95	Rain Tight	FRC, CI, AL	Yes		88 / 40

### Composite Base Models

Model #	Gal/Liter	Cover Type	Cover Material	Drain	Special	lbs. / kgs.
705-471-01	5/19	Rain Tight	FRC, CI, AL	Yes		38 / 17
705-478-EX	5/19	Rain Tight	FRC - Gray	Yes	Locking Fill Adaptor & Collar - poly gravel guard	40 / 18
715-471-01	15/57	Rain Tight	FRC, CI, AL	Yes		46 / 21
725-471-01	25/95	Rain Tight	FRC, CI, AL	Yes		76 / 34

### Slip-On Models (Retrofit)

Model #	Gal/Liter	Cover Type	Cover Material	Drain	Special	lbs. / kgs.
702-400-01	5/19	Rain Tight	FRC, CI, AL	Pump		34 / 15
702-404-65	5/19	Rain Tight	CI	Pump	ULC Listed	38 / 17
702-405-01	5/19	Snap-On	FRC	Pump		33 / 15
702-405-65	5/19	Snap-On	FRC	Pump	ULC Listed	33 / 15
702-406-01	5/19	Rain Tight	FRC, CI, AL	No		34 / 15
702-408-01	5/19	Rain Tight	CI	No	For 3" Riser	38 / 17
705-412-01	5/19	Snap-On	FRC		Flexible Entry Boot	34 / 15
703-400-01	5/19	Rain Tight	FRC, CI, AL	Pump	Stainless Steel	47 / 21

### Replacement Covers for Grade Level Spill Containers

Part #	Description	Color Chart (XX)
705-430-00	Cast Iron Cover	01 - Black
705-409-00	Aluminum Cover	02 - White
705-440-01	Cast Iron Cover with Gasket	03 - Red
705-420-02	FRC Cover - White w/Black Cross - Regular Unleaded	04 - Blue 05 - Yellow *
705-420-03	FRC Cover - Red w/White Cross - Premium Unleaded	06 - Gray * 07 - Orange *
705-420-04	FRC Cover - Blue w/White Cross - Midgrade Unleaded	08 - Green * 09 - Brown/Bronze *
705-423-XX	FRC Raintight Cover (XX - see color code for item #)	<i>* consult factory for availability</i>
705-333-XX	FRC Snap-On Cover*	<b>Listings:</b>
710-430-01	Aluminum Watertight Cover	ULC: File CMH1667
702-303-01	Aluminum Watertight Cover for 702 Models	C.A.R.B.: Order # 93-7, 96-1, 96-4

*\*Snap-On Covers only fit on Snap-On Spill Containers*