

Foot Valves Extractor

Model 320 Foot Valve Extractor

EBW's 320 foot valve extractor is designed for use with EBW's model 150 & 156 1 1/2 inch foot valves. The extractor valve provides a means to remove foot valves easily from underground storage tanks for cleaning or servicing. The model 320 foot valve extractor is gasket sealed to prevent loss of prime caused by air being sucked in through the top fitting.

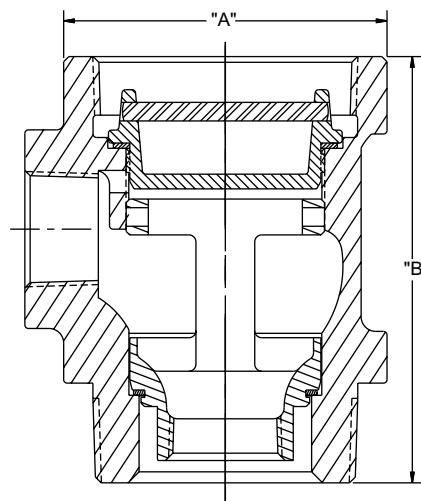

Part no.	Inlet Female Thread		Dim A		Dim B		Outlet Thread		Top Thread		Inlet Male Thread		Size		Weight	
	in.	mm.	in.	mm.	in.	mm.	in.	mm.	in.	mm.	in.	mm.	in.	mm.	lbs.	Kg.
320-302-01	1.5	38	5.50	139.7	7.25	184.15	1.5	38	4	102	4	102	4 x 4 x 1 1/2	102 x 102 x 38	20	9.07
320-302-02	1.5	38	5.50	139.7	7.25	184.15	2	51	4	102	4	102	4 x 4 x 2	102 x 102 x 51	20	9.07

Materials

Body: Cadmium plated cast iron

Cap: Bronze

Suction Stub Adaptor: Bronze

Gasket: Leather

Replacement Parts

Part No.	Description
320-102-01	Suction Stub Adaptor
320-103-01	Cap Assembly
321-100-01	Extractor Wrench

