

# Below Grade Spill Containers

## EBW's 702, 705, 715 & 725 Series FlexCatch® Below Grade Spill Containers

EBW's FlexCatch Spill Containers are designed to collect spilled product that occurs during normal tank filling on underground storage tanks. This usually occurs at the fill and vapor connections or in the event of a tank overflow. EBW's Below Grade Spill containers come equipped with a hinged, locking, watertight cover eliminating water and debris infiltration. A grade level manhole with FRC cover is installed above the spill container to allow surface water to drain into the soil and away from the spill container. EBW offers three base styles to choose from depending on your installation requirements. Threaded base models are offered in Cast Iron or Composite. Slip-On (Retrofit) models use a gasketed flanged bolt system to secure the spill bucket to the riser pipe. Slip-On (Retrofit) models are designed to eliminate the need to remove the riser pipe from the underground tank when installing. The tank is simply slid over the existing 4" riser pipe and secured in place with a flanged bolt system.



### Features:

#### **Watertight Design**

The hinged, locking, watertight cover and solid body design eliminates any rainwater from getting into the spill container.

#### **Cast Iron or Composite Base**

EBW's base design is the most reliable in the industry. The polyethylene shell is bolted between the cast iron or composite base, a durable cork gasket and special backer plates ensuring a long lasting, watertight seal. Both bases easily thread onto a 4" tank riser.



#### **Many Cover Options**

EBW's colored composite covers help prevent cross contamination and eliminate the need to constantly paint by molding the permanent color into the cover. All spill containers are supplied with a black FRC (Fiber Reinforced Composite) cover (781-304-01) unless otherwise specified. FRC colored covers are available in all API color codes. Steel covers (781-306-01) in lieu of FRC Colored Covers are optional at no additional charge.



#### **Drain Valve**

The specially designed drain valve allows emptying of contained product back to the storage tank without messy plugs or pumps. By pulling the key ring located towards the top of the spill container, the valve pushes open to allow product to drain. The drain is equipped with a screen for convenient cleaning.

#### **Cover Actuated Push Drains (C.A.P.D.)**

As the spill container cover is closed and locked in place, the drain is automatically activated allowing any spilled product to drain into the tank.

#### **Auto Drain**

Conforming to certain state and local regulations, the Auto-Drain is a ball float drain valve that automatically allows product to drain when the product is present.

# Below Grade Spill Containers



## Cover Identification Plates

All FRC Colored covers have a recessed area on the top for a product identification plate. The identification plate clearly identifies the product contained in the storage tank. Identification plates are available for all standard API Symbols.

## Highway 20 Rated (DOT H20)

All EBW Spill Containers and Manholes exceed the D.O.T. H20 requirements.

## Capacity

EBW Below Grade FlexCatch Spill Containers are available in 5 gallon, 15 gallon, and 25 gallon capacity.

## Materials

Base: Cast Iron or Composite

Bucket: Polyethylene

Manhole Cover: Fiber Reinforced Composite (FRC), Steel

Cover: Cast Iron

## Centering Ring

All Below Grade Level Spill Containers come with a special styrofoam centering ring that is used during installation to easily align the grade level manhole with the below grade spill container.



**705 BG**



**715 BG**



**725 BG**

MODEL	A IN / CM	B IN / CM	C IN / CM
705	13.00/33.02	13.75/34.92	17.69/44.93
715	13.00/33.02	22.00/55.88	23.44/59.54
725	13.00/33.02	27.00/68.58	24.40/68.58

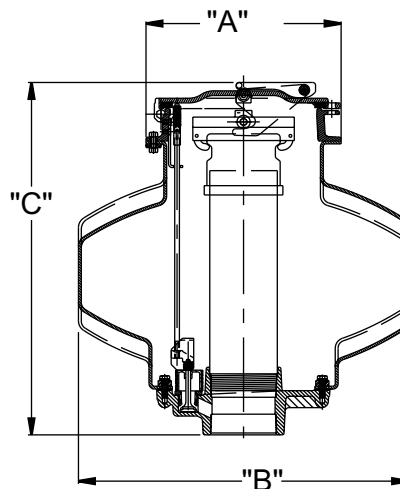

# Below Grade Spill Containers

## Ordering Specifications:

### Cast Iron Base Models

Model #	Gal./Liter	Drain	Cover & Skirt	Special	Lbs./Kg.
705-445-01	5 / 19	*CAPD	18" FRC Cover - 8 1/2" Skirt		94 / 43
705-474-01	5 / 19	Yes	18" FRC Cover - 8 1/2" Skirt		94 / 43
705-474-65	5 / 19	Yes	18" FRC Cover - 8 1/2" Skirt	Riser, Cap, Brass collar included, ULC	124 / 56
705-477-65	5 / 19	Yes	18" FRC Cover - 8 1/2" Skirt	Riser, Cap, Brass collar included, ULC	124 / 56
705-495-N	5 / 19	Yes	None Included		64 / 29
705-438-06	15 / 57	Auto	18" FRC Cover - 8 1/2" Skirt	NYC	94 / 43
705-439-01	15 / 57	Yes	18" FRC Cover - 5 1/2" Skirt	NYC Shallow Burial-Stainless Steel Tank	110 / 50
715-446-01	15 / 57	*CAPD	18" FRC Cover - 8 1/2" Skirt		85 / 39
715-474-01	15 / 57	Yes	18" FRC Cover - 8 1/2" Skirt		96 / 44
715-474-65	15 / 57	Yes	18" FRC Cover - 8 1/2" Skirt	Riser, Cap, Brass collar included, ULC	100 / 45
725-474-01	25 / 95	Yes	18" FRC Cover - 8 1/2" Skirt		112 / 51

\*Cover Actuated Push Drain

### Composite Base Models

Model #	Gal./Liter	Drain	Cover & Skirt	Special	Lbs./Kg.
705-475-01	5 / 19	Yes	18" FRC Cover - 8 1/2" Skirt		82 / 37
725-475-01	25 / 95	Yes	18" FRC Cover - 8 1/2" Skirt		100 / 45

### Slip On (Retrofit) Models

Model #	Gal./Liter	Drain	Cover & Skirt	Special	Lbs./Kg.
702-450-01	5 / 19	Pump	18" FRC Cover - 8 1/2" Skirt		61 / 28
702-450-65	5 / 19	Pump	18" FRC Cover - 8 1/2" Skirt	ULC	61 / 28

### Replacement covers for Below Grade Spill Container Manholes

Model #	Description	Color Chart (XX)
781-304-XX	FRC Cover (XX-see color chart)	01- Black
781-306-01	Steel cover	02- White
		03- Red
		04- Blue
		05- Yellow *
		06- Gray *
		07- Orange *
		08- Green *

\* consult factory for availability